



**Wombourne Windows™**  
ORANGERIES AND CONSERVATORIES



Welcome to **Wombourne Windows™**  
ORANGERIES AND CONSERVATORIES

The Wombourne Windows collection, offers exceptional glazing solutions, meticulously designed to transform your home and living space into something truly extraordinary.

From our Signature 2 range of casement windows to our Wodehouse bespoke joinery flush windows, our bespoke conservatories and orangeries we offer a unique solution to you and your home.

Every product in the Wombourne Windows collection, is designed and built specifically for each individual customer, handcrafted to your exact specification.

Our ethos is one of exceptional design and product performance, created to compliment the home and the lifestyle of our customers. We believe in producing solutions that will delight customers now and for years to come.

We have an excellent reputation, where attention to detail and superb British craftsmanship is second to none.

We thank you for taking the time to look at our products and we look forward to working with you.

*Wombourne Windows*

# CONTENTS

1. ABOUT US
2. OUR SIGNATURE 2 WINDOWS
3. SIGNATURE 2 PVC DOORS/ FRENCH DOORS/PATIO DOORS
4. WODEHOUSE FLUSH CASEMENT WINDOWS
5. WODEHOUSE PVC DOORS
6. ARCHITECTURAL SERVICES AND LEGAL RESPONSIBILITIES
7. CONSERVATORIES, CONTEMPORARY ORANGERIES, ORANGERIES AND TILED ROOFS
8. ORIGIN BIFOLD DOORS
9. BYGONE SASH WINDOWS
10. ORTON & HIMLEY TIMBER WINDOWS AND DOORS
11. AL-ELEGANCE
12. TECHNICAL DOORS
13. ROOFLINE PRODUCTS





# ABOUT US

Wombourne Windows Ltd has traded successfully since 1982. The founder, Mick Mills, is still actively involved and continually ensures that we keep ahead in Product Development.

It is our responsibility to give you a professional design service as well as a unique product range that will be in keeping with the style and age of your property and enhance the value of your home.

With nearly four decades installing Conservatories and Orangeries we have seen the legal requirements change beyond recognition. As a home owner there are a myriad of responsibilities and applications needed to keep your project legal, from planning permission to building control, water board applications, and structural calculations. Wombourne Windows has always applied the best practices to all our structures to the point we keep our professional architects on retainer to advise and complete all required permissions and applications to bring your project to a quality and legal conclusion.

The technical survey is the most vital part of your project and often underestimated in our industry. A precision survey means that the installers enjoy their work and the windows & doors fit your brick openings with minimal sealants & trims, giving you the perfect finish.

We understand that having done all the preparation, the installation, finishing detail & completion of your project is the most important stage of all. This will be taken care of by one of our own teams of highly trained & experienced craftsmen. We have a very low turnover of staff, meaning that each member of our team understands our philosophy of delivering excellence. We have a dedicated After Sales Department running full time Service Engineers with a computerised record of every window & door that we have installed dating back to 1982. This ensures we can identify, replace or repair any item.

The reason we are still going from strength to strength is that we look after our customers. More than 50% of our work comes from people recommending us or returning for additional work.

We can promise you will be delighted with every aspect of the process and we look forward to being of service to you.

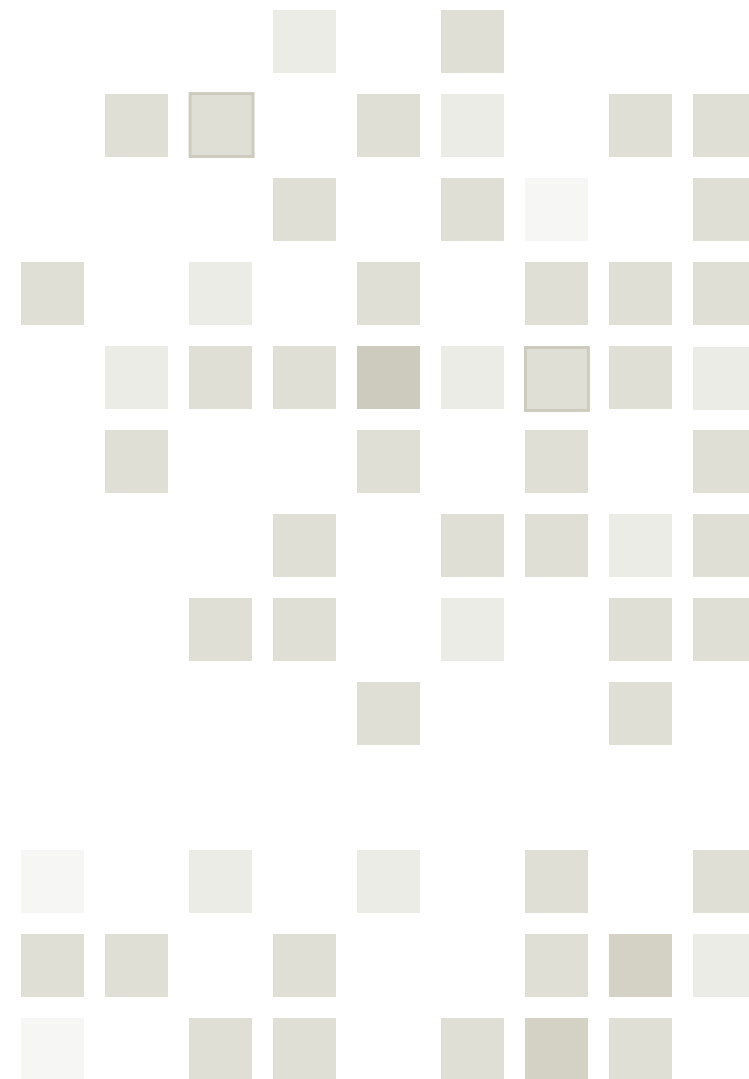









*Signature 2*  
WINDOWS



# Signature 2 WINDOWS

The success of our Signature 2 brand is largely down to the many features that will not only enhance the appearance of your home, but also the security and energy efficiency. The homes that inspire us are the ones that reflect our personalities. We all have different lifestyles, favourite colours and tastes.

## Signature 2 Profile Finish Options

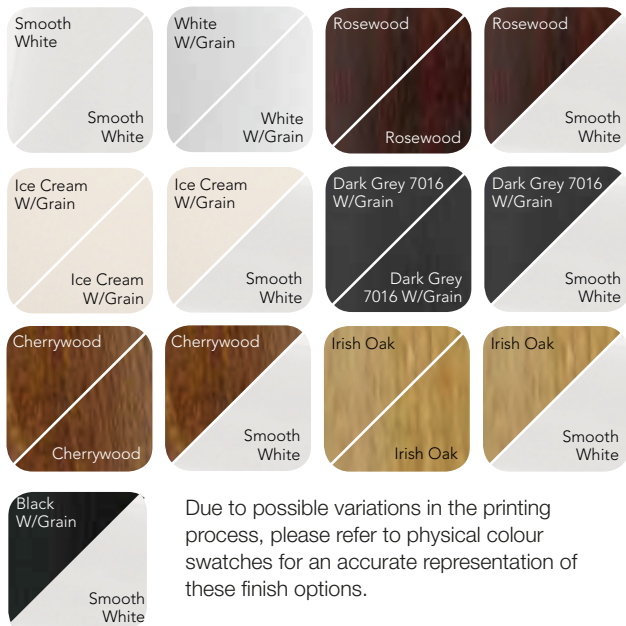

If you would like a colour that is not within our range of woodgrain foils, we can arrange to have your windows or doors spray painted in the colour of your choice. You can choose to have the colour applied to both the inside and outside faces, or outside only leaving a fresh white internal finish.



Irish Oak Finish with Dark Grey 7016 Entrance Door



Ice Cream Woodgrain Windows with Georgian Bar detail



Close up showing the realistic black woodgrain effect



Grey working well with cream exterior render



### Maximise the Opening

The owners of this property wanted to maximise the size of the opening of the kitchen window.

The solution was a cottage style window complete with a floating mullion. We used a floating mullion window it is purposely designed to house the locking system so a central fixed vertical mullion is not needed between the two opening sashes.

When the windows are fully open, you get the maximum benefit and when the windows are closed, the floating mullion gives the appearance of a fixed frame between the two opening sashes.

## Why Choose *Signature 2*?

In order to meet the governments thermal performance targets and current Building Regulations, all replacement PVC-u windows are to achieve a U-value not exceeding 1.6 (W/m<sup>2</sup>.K), therefore certified to Energy Rating 'C' or better.

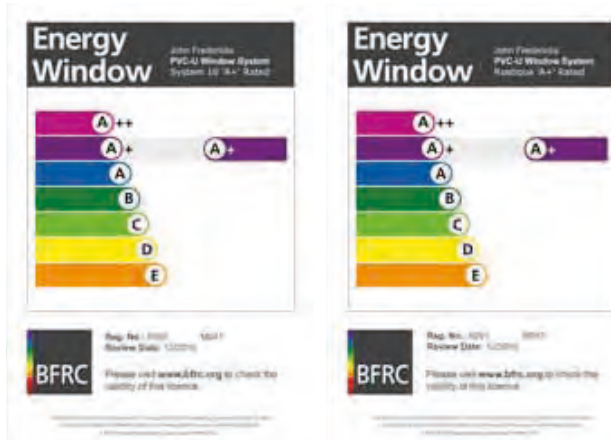

*Signature 2* windows achieve an A+ Energy Rating with an Energy Index of 10 and a U-value of 1.4 (W/m<sup>2</sup>.K).

High Quality PVC-u Material, Technically Superior Profile System

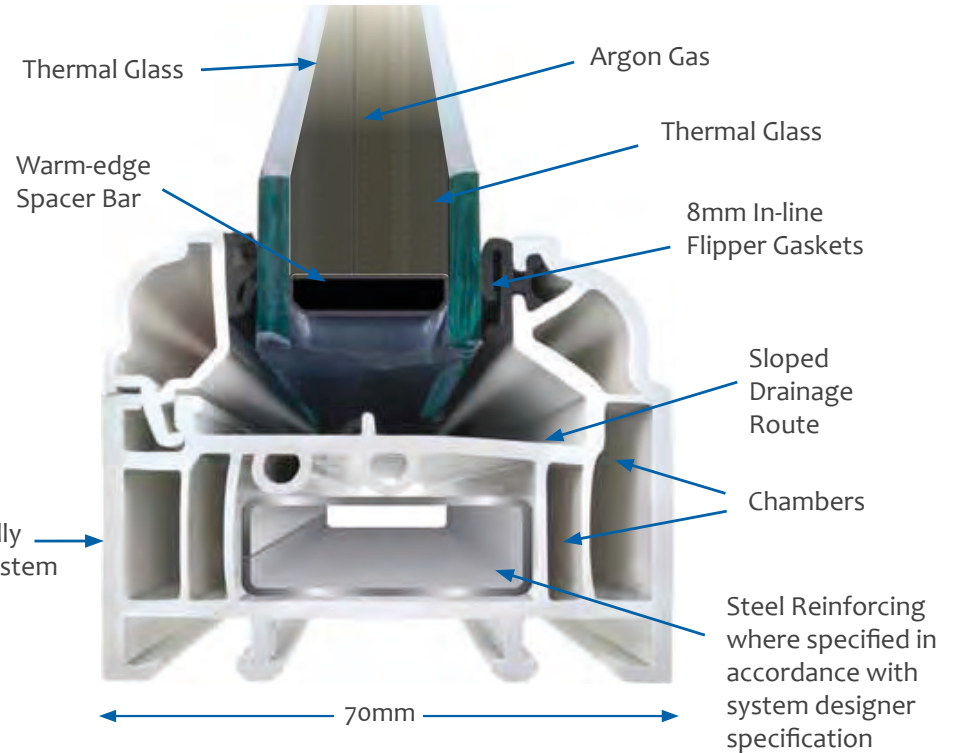

Reduce home heat loss and save money with *Signature 2* Energy Efficient Windows.

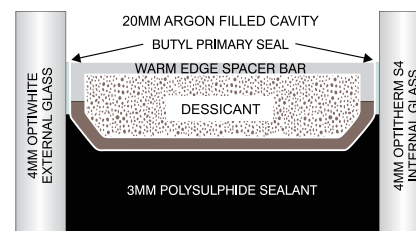

Typical A-Rated Sealed Unit

The red glow shown left, on the internal face of the entire window area symbolises the amount of heat Ultimate windows retain. As a result, the inside of your property remains warmer and more energy efficient.





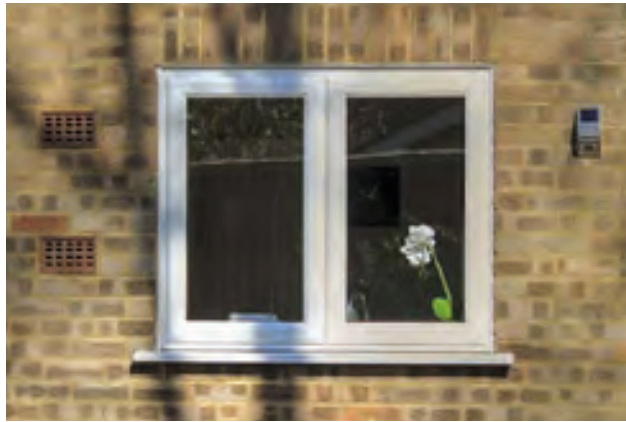

The floating central mullion allows the windows to benefit from the maximum opening without the obstruction of a fixed vertical frame between the opening sashes.



## *Signature 2* Security

The Signature 2 window has been refined and designed to protect you and your home and provide you with total reassurance and peace of mind.

The locking technology at the heart of every casement window incorporates 10 security features (subject to casement size).

A total of 10 security points, in all four directions

2 x steel shoot bolts

4 x central collared cams

2 x high security hinges

2 x 15mm anti-jemmy hinge bolts



BS 7412/PAS 24  
KM 36015



Steel Shoot Bolts



Collared Cams



High Security Hinges



15mm Anti-jemmy Hinge Bolts

## Signature 2

### Authentic External Astragal Bar

You may decide to have decorative Astragal Bars applied to your windows for the truly authentic Georgian style.

The unique Signature 2 Astragal bar is a scribed PVC-u bar, finished and colour matched to the exact same finish of your chosen windows.

The bars are connected to full length aluminium fixing strips that are bonded to the glass unit. This, combined with the spacer bar grid design inside the unit, gives the impression that each pane is a separate unit.

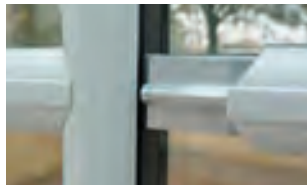

The innovative Ali-lock bar system ensures the Astragal grille does not shrink, warp or detach, regardless of weather conditions.



### Versatility in Design

In order to cater for the diverse mix of property styles and consumer preferences, windows and doors are now available in a wide variety of styles and finishes. Using a combination of top openers, side openers and fixed panes, the range of styles is immense so you are sure to find a design to suit your home.

Similarly, there is no reason to compromise when replacing bay windows. Not all bay windows are the same, some require load bearing support. Our Signature 2 windows offer load bearing support components to suit both 90° bay windows and multifaceted bays. Using our versatile bay posts, a variety of combinations can be assembled to achieve the correct angles.



## Internal Georgian Bar

In contrast to the Signature 2 External Astragal Bar system where the bar is applied onto the outer faces of the insulated glass unit, as the name suggests, Internal Georgian Bars are held within the sealed glass unit.

Internal Georgian Bars still provide an effective feature but with the bars inside the glass, the glass maintains a flat surface with no protrusions and are therefore easier to clean.

## Smart Safety Solutions

For your safety, easy clean/fire escape hinges are fitted as standard to all side-opening windows. These will open fully to give you an alternative means of fire escape (dependent on window size) and can slide towards the centre to allow easy external cleaning.

Turn the slot-bolts located on the top and bottom hinges 90° and simply slide the window across for easy external cleaning. The window will automatically realign upon closing.

The unique dual purpose key can be used to lock your window handle and to operate the hinge slot-bolts as shown right.

Key release fire escape/easy clean mode.



## Dummy Casements Provide Equal Sight Lines

The owners of this property have chosen to have opening sashes in the tops of the windows and fixed dummy casements in the lower half. Viewed from the outside all appear to be opening windows and therefore help to maintain a neat, balanced symmetry throughout the property known as equal sight lines.

The below example clearly shows how dummy casements help to achieve equal sight lines. The left image shows opening sashes either side of a fixed pane. The right image also only has opening sashes either side but a dummy casement has been added in the centre to provide equal sight lines and give the impression of three opening sashes.





# Signature 2 Handles and Furniture

## Window Handles



White Black Gold Chrome Satin



Chrome Teardrop Handle Gold Teardrop Handle Graphite Teardrop Handle Antique Black Teardrop Handle



Chrome Monkey Tail Handle Gold Monkey Tail Handle Graphite Monkey Tail Handle Antique Black Monkey Tail Handle

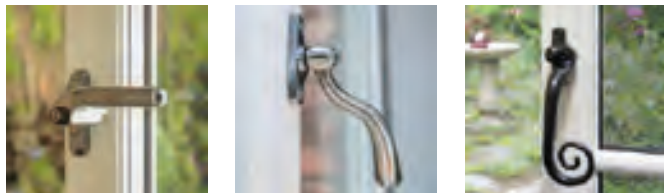

## Door Furniture



White Black Gold Chrome Satin



Pad Handle (available in all finish options)



Victorian and Slim Victorian Urn Knockers (available in all finish options)



Escutcheon Finger Pull (available in all finish options)

## Handle Options

## Letter Box Options



White



Black



Gold



Chrome



Satin

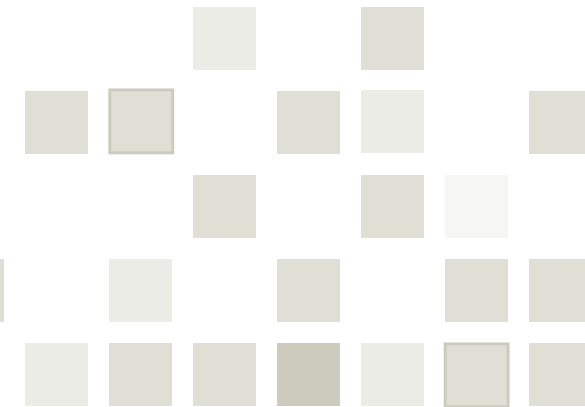

# Signature 2 DOORS

Choosing the right entrance door for your home is an important decision as your front door creates the first impression and the all important kerb appeal. Your choice of door and glazing design can help define the overall style of your home and add light to an otherwise darkened hallway.

Allow yourself time to decide what is right for your home, whether it be traditional or contemporary you are sure to find a style that suits.

Signature 2 doors give you almost endless style and colour choices, so now your door can really reflect your personality. With the vast choice of finish options and an elegant range of door furniture, it's now possible to emulate most timber door styles in PVC-u.



## Door Security

For your security, Ultimate Bespoke Doors are fitted with a robust 12/14 point multi-lock.

Ultimate 12/14 Point Lock

2 x top and bottom shoot bolts.

3 x outer/inner facing hook locks.

2 x dead locks.

1 x centre locking latch.

4/6 x roller cams (dependent on door height).

Plus 2 x Optional Anti-jemmy Hinge Bolts

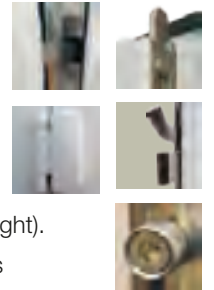

To prevent cylinder manipulation, Ultimate doors are fitted with a 3 star high security Yale cylinder, and for convenience all doors are supplied with 5 keys as standard.



*the ultimate*  
collection  
Partnership secured with 



## Townhouse Lock Option

As an alternative to the standard locking system, you may wish to consider our townhouse lock option. The townhouse lock is completed with a traditional escutcheon finger pull. This option also includes the high security cylinder as detailed above.



## French/Double Doors

French Doors, often with full height glazing can provide additional light to a room. They are used both internally as a partition from one room to another or externally to provide elegant access to the garden.

These door styles will also provide a practical wider opening, particularly useful when moving larger items to and from the

property. When the opening is too narrow for a Bi-fold or Patio Door, French Doors can often be the perfect solution.

All Signature 2 French Doors include the same multi-point lock that is fitted to single doors with additional shoot-bolts fitted to the slave door.

## Sliding Patio Doors

Modern day comfortable living comes in a variety of forms. Where light and space is key, large glass surface areas such as Sliding Patio Doors will help to bring in more light and provide that contemporary spacious feel.

They are particularly suited to rooms restricted in size or space with the doors sliding horizontally and therefore not encroaching on internal space.

Security is covered with opposing hooks locks, internal/external locking, aluminium inter-lock section and anti-lift device.











# Wodehouse FLUSH WINDOWS



# Wodehouse WINDOWS

## The Alternative to Timber

As the name suggests, our Wodehouse Collection is a range of elegant windows and doors that are packed with the characteristics and charm of period timber windows. Less obvious perhaps is that every window and door shown throughout this brochure is manufactured, not with timber but using a specialist range of advanced PVC-u profiles. Indeed, this Flush Sash window is assembled using traditional joinery techniques.

Considerable care has been taken to capture the charm and elegance of timber, even down to the tactile woodgrain finish, but combine this with the advanced low maintenance qualities associated with modern day PVC-u products.

This versatile collection includes a number of options from the fundamental choice of sash style through to your choice of finish from the subtle colour palette. The result of this is a range that will suit a multitude of property styles and this will be evident as you browse through this brochure.



Scribed and milled butt joints on both outer frame and Flush Sash.

Wodehouse Windows with timber style Joinery Engineered using traditional joinery techniques with scribed and milled butt joints providing the ultimate timber effect window. White Woodgrain sculptured finish inside.

## The Wodehouse Colour Palette

In previous years it was a given that new windows would always be replaced with like-for-like, which in most cases meant white PVC-u.

But in recent years there has been a colour revolution and whilst white PVC-u is still going strong, today there is a myriad of other options available from dark anthracite greys, through to beautiful and elegant creams, all the way through to soft greys and greens.

Regardless of your property style and age our Wodehouse Collection allows you to make a statement with colour on the outside but still maintain a fresh but subtle white woodgrain finish on the inside. French Grey or Agate Grey might work to enhance your property from the outside, but white is incredibly versatile as an interior colour and works well with just about any colour scheme, which will inevitably change over time.

Consider the character of your property – some properties in the UK will be bound by listed building rules that prohibit certain decisions around a property's exterior appearance – while this is unlikely to be the case in many instances, it's



always wise to consider the age and style of your property before you make your final decision.

There are many properties in the UK that would really benefit from the use of these alternative shades to enhance their period features – so don't be afraid to explore this option. Likewise, if your mid-50s semi is crying out for a style statement, you might want to consider a smooth anthracite grey – against a traditional British brick, the grey is incredibly pleasing on the eye and can deliver an instant wow to any property.



Due to possible variations in the printing process, please refer to physical colour swatches for an accurate representation of the above colours.

## Security

The very latest security features have been engineered to fit all styles of our Wodehouse Windows, to ensure your safety and security is never compromised.

With the simple turn of a handle, every window is secured by a multi-point locking system, securing points on all four sides of the opening sash, giving you complete reassurance and peace of mind.

For your safety, easy clean/fire escape hinges are fitted as standard to all side-opening windows. These will open fully to give you an alternative means of fire escape (dependent on window size) and can slide towards the centre to allow easy external cleaning.

Turn the slot-bolts located on the top and bottom hinges 90° and simply slide the window across for easy external cleaning. The window will automatically realign upon closing.

The unique dual purpose key can be used to lock your window handle and to operate the hinge slot-bolts as shown.

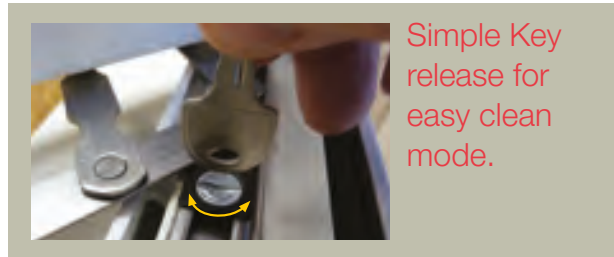

For the ultimate timber look window, you have the option of choosing our Wodehouse flush sash complete with timber look joinery. These windows look, feel and are made just like their timber counterparts.



Scribed and milled butt joints to both the inside and outside of the outer frame and sash make it difficult to distinguish these from timber windows.



BS 7412  
KM 36014



BS 7412/PAS24  
KM 36015





Wodehouse Flush Sash in Cream, installed in a conservation area.







# Wodehouse PVC DOORS

# Wodehouse

## PVC DOORS

The Wodehouse Door Collection includes a range of 25 versatile PVC-u door styles, thoughtfully designed to emulate the aesthetic character of timber doors but with the added security benefits and low maintenance qualities that modern day living demands.

You have the choice from a range of standard finish options to match our Wodehouse windows. The diverse range of available door styles from classic to contemporary combined with the broad colour palette available makes it easy for you to create the perfect entrance to your home.

### Optional Deep Feature Midrail

A number of styles in the Wodehouse collection have been designed to closely emulate traditional timber doors and are therefore suited to include the Deep Featured Midrail option. Deeper in proportion, this option is more in keeping with the appearance of typical timber door designs.



The Lavenham, including Deep Feature Midrail.



Hadleigh Style.



Ixworth Style.





## Door Security

For your security, Ultimate Bespoke Doors are fitted with a robust 12/14 point multi-lock.

Ultimate 12/14 Point Lock

2 x top and bottom shoot bolts.

3 x outer/inner facing hook locks.

2 x dead locks.

1 x centre locking latch.

4/6 x roller cams (dependent on door height).

Plus 2 x Optional Anti-jemmy Hinge Bolts

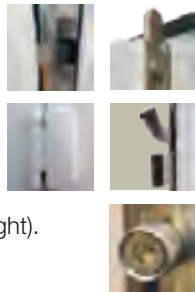

To prevent cylinder manipulation, Ultimate doors are fitted with a 3 star high security Yale cylinder, and for convenience all doors are supplied with 5 keys as standard.



**theultimate**  
collection

Partnership secured with **Yale**



## Heritage Lock Position Option

As an alternative to the standard locking system, you may wish to consider our Heritage lock option. Heritage Lock position is completed with a traditional escutcheon finger pull. This option also includes the high security cylinder as detailed above.



Bevelled glass and lead combination.

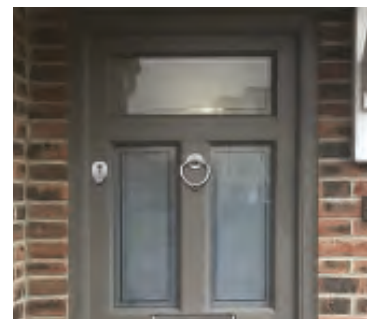

Elegant clean lines achieved with an etched glass design.

Our door range not only gives you a terrific choice of colours and designs but the flexibility of our glazing options allow you to either 'go create' a new look or stay classic and authentic.

The options are simply vast and include plain glass, obscured, coloured, etched glass, leaded and bevelled designs. All of these include a multitude of variations so you are sure to find something to suit the style of your door and property.

## Astragal Bar Design

Our authentic Astragal Bar design will instantly create the period look. Because the bars are fixed to full length aluminium backing strips, there is no risk of the bars warping or bending.

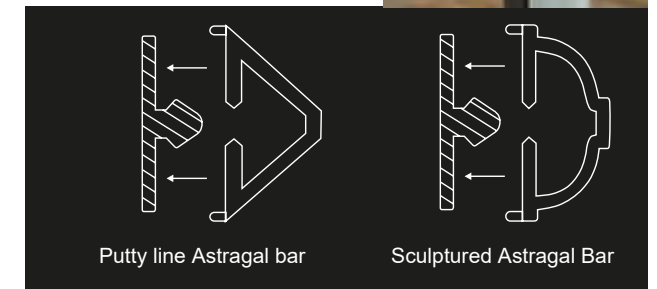

Putty line Astragal bar

Sculptured Astragal Bar

## Glass

Glazing is one of the most important aspects of any window. It can be transparent or opaque, stained or coloured and can even showcase geographical patterns and fashion trends.

Glass can say a lot about a window, which in turn can tell you a lot about the property and its inhabitants. Traditionally, large panes of glass meant wealth, due to the complicated nature of glass production in the 17th Century. Smaller panes were often saved for shop fronts and included bulls eyes, the centre of the spun glass and the cheapest part.

Stained glass and overly complicated Georgian bar designs were similarly a sign of wealth in Victorian Britain and there are examples of this all over the country, but especially in the capital and more salubrious areas.

Aged lead occurs less in sash windows, but is still occasionally seen. Leaded glass often means a lot more weight in the window and can often have a negative impact on thermal efficiency. Glazing itself has had to change with the times and other qualities are now more important to the modern home owner. These include acoustics, thermal efficiency, security and durability, often dictated by ever changing building regulations and planning laws.

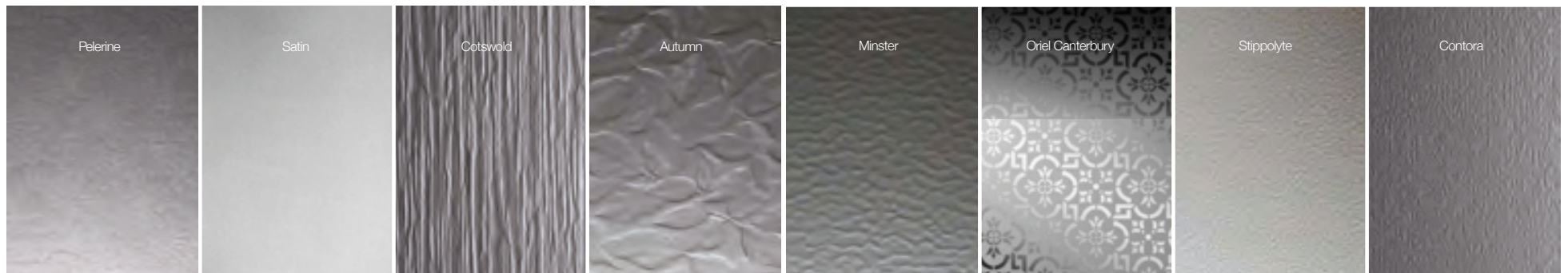





# ARCHITECTURAL SERVICES AND LEGAL RESPONSIBILITIES

# ARCHITECTURAL SERVICES

## Architectural Services and Legal Responsibilities

When you consider your new project, your responsibilities as a home owner are to make sure that all the legal requests are taken care of and completed, the constant legal and permission changes in what is required to make you new structure legal means that advise at the decision making stage is so important, it makes the difference of a trouble free experience or a potential money pit after the contractor has left, and in some cases either the structure having to be removed or the property not being able to be sold at a later date. Or at worst being illegal!

That's why at Wombourne Windows we have our own architects on retainer, giving a professional service, and advise to make sure the likes of:-

- Do I need planning permission for my structure?
- Do I need planning permission for my windows?
- Do I need a conservation application?
- Do I need building control?
- Have I got to make an application to the local water board?
- Do I need structural calculations?
- Can I take the doors/walls from my home to the new structure out?
- Do I need a SAP report

And many more!







# CONSERVATORIES & ORANGERIES



# CONSERVATORIES & ORANGERIES

## Wombourne Windows Most Loved Glass Conservatory Roof

Developed over 30 years and engineered to postcode, the Classic conservatory roofing system provides high quality, reliability, and is highly configurable making it the go-to solution for every conceivable glass conservatory roof design.

Ultraframe's specialist software engineers every critical element of the roof to withstand wind the most extreme wind and snow loads that are specific to the installation postcode.

Manufactured in Britain, the Classic roof is fully BBA approved with over 1.5million roofs installed throughout the UK over the past 35 years.

Patented chambered top caps combined with twinbolts and the sturdiest, most durable gaskets and glazing stops ensures the roof can withstand winds up to 130mph.

Pitches available from 2.5° to 40.9°, variable ridges and portal systems also means the Classic roof is configurable to almost any size and shape.

Compatible with Ultraframe's insulated pelmet, cornice and super-insulated columns and available in any colour and an unrivalled range of glazing options.

Ultraframe's patented adjustable speedlocks optimise glazing bar compression and make the roof simple to fit ensuring a fast fit, first time, every time.



## Performance Engineering

- Barbs on uPVC top cap are retained inside aluminium structure - enhanced security, will not loosen on expansion.
- High strength twin wall chambered top cap offers improved thermal performance and reduced risk of condensation.
- Optional chambered top cap (choice of 2) resists bowing and twisting.
- Multi chamber 'wine glass' shape aluminium offers more torsional rigidity and solid, secure jack rafter connections.
- 10mm TPE hidden flipper gasket - adjusts to tolerance in the glazing material.
- Security of 2 bolts per position - fixed bolt position resists bar slippage.



- EAVESFLOW
- Eavesflow sits within the eaves beam, introducing clean fresh air to replace the warm moist air that exits through the ridge.



## Glazing

To enable a conservatory to be used all year round, a glazing material must be selected that deflects heat from the sun in the Summer and retains the warmth from heating appliances in the Winter. Also needed is a material that allows maximum light into your home.

- Our sealed units offer a range of performance attributes - perfect for roofs
- All roof units use toughened safety glass: 4mm glass - 16mm Argon filled cavity - 4mm glass with black warm edge spacer as standard.
- All roof units are manufactured in specialist roof glass factories and include the Wombourne Windows industry beating warranty for 20 years.
- All glazing specifications are true 'self-cleaning' and offer a range of solar control properties. With a range of colours from our Aqua top of the range, to the blue shade, and clear.

## Glazing Bar Anchor Clips

A natural characteristic of a roof consisting of an aluminium core with PVCu top caps is differing expansion and contraction. We provide a tried, tested and patented solution to give long term peace of mind to maintain the critical weather tight seal.

## Opening Roof Vents

A roof vent is one of the fastest ways of ventilating a conservatory during the warmest months of the year.

Roof vents are thermally broken to ensure optimum thermal performance and boasts a PVC welded frame to eliminate any chance of leaks.

Available on all of the Ultraframe and roofing systems with a choice of manual openers, electronic openers and electric openers with thermostat and rain sensor.

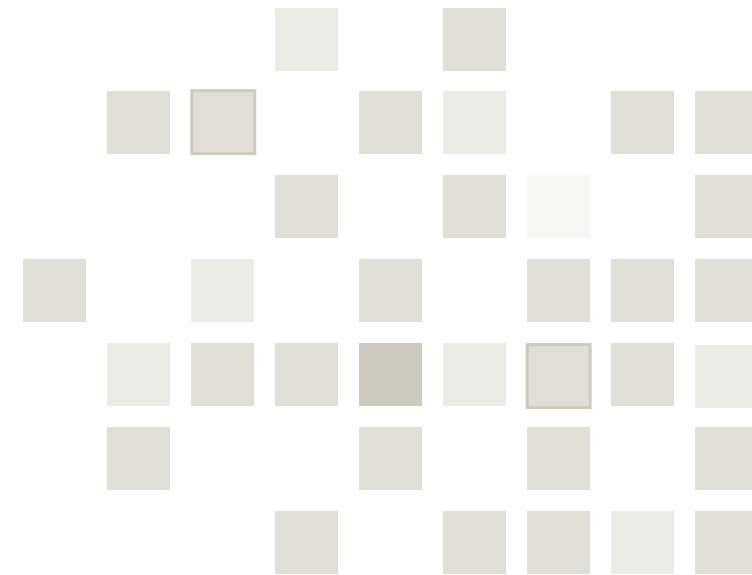





## Ground Preparation

- Before the ground floor can be constructed, the ground must be prepared to ensure the slab has consistent support.
- Topsoil and any vegetable matter will be removed from the site. It is easily compressed and may sink, causing the slab to settle and crack up.
- Pre-existing foundations must be appropriately dealt with, and removed.
- All precautions will be taken against ground contaminants, gases, landfill gases, radon, vapours etc.

## Foundations

A foundation is required to ensure loads from the building are sustained and safely transmitted to the ground. All load bearing elements.

## Foundation Depth

- The foundation trench will be excavated down to consistent and competent virgin ground which will provide adequate bearing strength.
- In chalk soils, foundation depths can be as little 750mm. (This depth of foundation is our standard depth foundation)
- In sand and clay soils, the depth of foundations will be no less than 900mm deep and BS8103 recommends a depth of not less than 1.0m. (This depth of foundation will be used when construction is under LABC)
- In clay soils affected by seasonal moisture, foundations over 2.5m deep are not normally acceptable, in which case piles, raft or pad and beam foundations may be required. (The requirement for a raft foundation may attract additional cost) Additionally, some soils can be affected by particular species of trees and deeper foundations or special foundation types may be required

## Hardcore

- To provide suitable material for the floor slab, a layer of clean hardcore at least 150mm thick but no more than 600mm is provided over the prepared oversite ground.
- The fill material used to make up the hardcore will contain nothing larger than about 100mm and be well graded inert fill without hazardous materials. It will contain a range of particles so that it can be firmly compacted, such as clean broken bricks, roof tiles, concrete or crushed stone, or ready-made loose granular material such as 'type 1' hardcore can be used.
- Our fill will be mechanically compacted using a small vibrating plate or roller, in layers no thicker than 225mm so that no air pockets are present and settlement is avoided.
- A layer of a minimum 20mm (but can be up to 50mm) of sand blinding will be provided over the hardcore before laying the concrete or DPM and will be essential to prevent sharp stones from puncturing the sheet DPM.

## Drains Near Foundations

- When we dig the trenches for the foundation, all existing services and nearby drains will be supported and protected.
- However, if the drain is no longer in use, it will be removed or opened up and filled with concrete
- The design of the foundations will account for the effect of any nearby drainage trench on the newly excavated foundations. Any service trenches or other excavations will be above the 45 degree line extending down from the bottom of the foundation, as shown below. NB Reference should also be made to NHBC Chapter 5.3 'Drainage Below Ground'.

## Strip Foundations

- The thickness of a strip foundation will be between 150mm and 500mm. 300mm thickness is used in most of our domestic works.
- Strip foundations are usually at least 600mm wide as this tends to be the width of the digger bucket although on sand, silt or soft clay, it may be necessary to provide foundations as wide as 850mm.

## Damp Proof Membrane

To prevent dampness getting through, a ground bearing concrete floor will be used and will be protected by an impervious layer, usually a 1200 gauge (0.3mm) heavy duty polythene damp-proof membrane.

- The DPM will be positioned either on the sand blinding or on the concrete slab.
- Joints in a Polythene DPM will be welded or taped and will overlap by at least 300mm.
- The DPM will be linked with the DPC in the walls, to ensure that the entire interior of the building is protected from moisture by a continuous, impervious barrier.
- The DPM will be dressed up around service entry points.

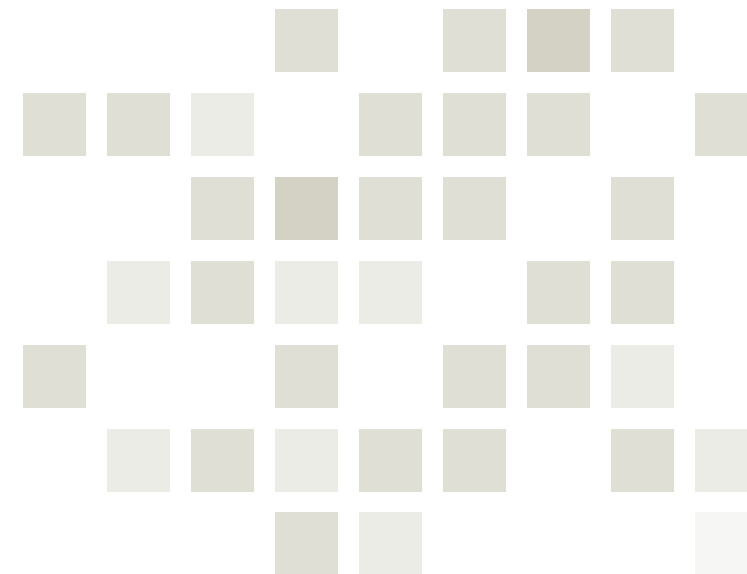



## Walls Below Ground

The concrete foundations will be allowed to cure for at least a couple of days before the external ground walls are constructed to DPC level.

- The walls, usually brick or block-work, will be built up in the centre of the strip foundations. At least 150mm projection of the concrete foundation is required at either side of the wall.
- Checks are made that the bricks or blocks are suitable for underground use. The blocks used below the DPC will be specified to comply with BS 5628 part 3.
- The mortar below DPC is for underground use.
- The cavity in the walls below ground will be filled with a weak concrete mix (stopped 225mm below horizontal DPC in the walls or cavity tray provided), to prevent the leaves being pushed together when the trenches are back filled.



## Raft Foundations

- As the name suggests, a concrete raft is designed to 'float' on the ground beneath. The structure is made up of an extra-thick floor slab, strengthened by masses on steel reinforcing. Rafts have the advantage of providing the base of a ground floor solution, not just wall trenching, but they are reckoned to be rather more complex to construct.
- A raft is used where the soil requires such a large bearing area.

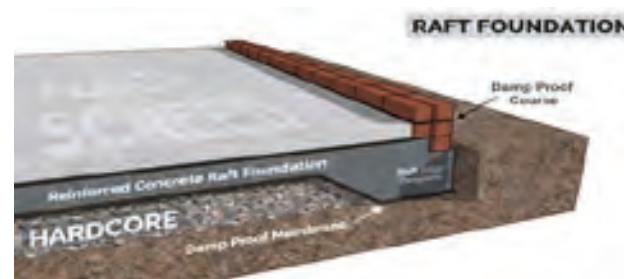

## Orangeries – Let the Outdoors, in

A luxury orangery enables you to appreciate the outdoors from the comfort of your home. Luxury orangeries trap the natural light, fend off the elements and enhance your home's natural surroundings, leaving you and your guests with a sense of space and tranquillity. No longer will the elements affect your al-fresco entertaining and on sunnier days you can simply throw open the doors to welcome the weather in.

## Bespoke Orangeries

Whether you are looking to house a kitchen or dining room, expand your living room or just need some stylish additional space for relaxing or entertaining, our team of expert designers can come up with solutions that perfectly fit your specifications.

## Costs

When looking at the associated costs with extending your home / living space with an orangery you have to look at the cost of the product as well as the installation costs. Again, this is very much a bespoke consideration as the cost to install will depend on the size of the structure and complexity of install (foundations, existing property features, and integrations).

Other factors that influence the total orangery cost will include:

- Whether you need to go through planning permission
- Building regulations
- Lantern roof size
- The foundation setting
- Integration with your existing property, this can include knocking through walls, RSJ/steel beam supports, and structural calculations
- Plumbing and electrical wiring
- Design process



All of the factors above will impact how much an orangery costs you so it is important to factor these in. Labour costs can tot up quickly.

Whilst an orangery can be an expensive investment, it can also increase the value of your property more than the initial cost, so bear that in mind.

Both orangeries and conservatories can increase the value of your home, but, with the additional structural features that an orangery can bring with a central roof lantern on a flat roof, orangeries can generally add more value to your property.

Orangeries tend to be more expensive than a similarly sized conservatory, but depending on the options chosen for framing and glazing, orangery costs can still be very reasonable. Our structures are of the highest quality, incorporating modern design features such as multi-point locking and adjustable hardware while retaining the clean and traditional aesthetic.

## Design

- Planning / permitted development approval.
- Building regulation acceptance.
- Structural calculations
- All groundwork's / foundations.
- Drainage.
- Brickwork / blockwork
- Plastering / rendering
- Electrical
- Heating
- Structural openings inc structural calculations.
- Complete installation of all orangery / conservatory components.

## Positive Approach To Finding Solutions

At Wombourne Windows we undertake all works associated with your new project to allow you the reassurance of dealing with one company from conception through to final completion, please find detailed a list of works usually carried out on typical installation for conservatories and orangeries.





### Contemporary Orangeries

The insulated internal pelmet is the best of both worlds, combining the light and sky views of a conservatory with the walls and ceiling of an extension ensuring your new hybrid orangery or extension is always warm, welcoming, and cosy.

Using the proven Classic glazed roof at its heart, an engineered framing system is added internally which is plastered to give a perimeter ceiling all the way round creating a look that is neither conservatory nor extension.



### Choice of Summer Gutter Finishes

A decorative cornice adds shape and style to any roofline, concealing gutters and rafter ends. Best of all there are 4 styles to choose from (1-tier flat cornice, 2-tier flat cornice, 3-tier flat cornice, curved cornice).

1, 2 & 3 tier flat cornices are available with 90° corners and straight jointers. The curved cornice includes a die cast 135° and 90° corner cover as well as straight jointers, which helps achieve a consistent fit and finish at critical junctions.

All cornices are available in a wide range of colours to match the specifications of your project.



## Orangery Flat Roof Structure – The Extension Project of Choice

Orangery extensions are an increasingly common project that we see across our desks here at Wombourne Windows. With little impact on the existing property and often without the need for time-consuming wrangling with planning departments, this method of extending your home is both quick and easy.

Large roof windows or lanterns and glazed walls allow you to bring the outside in and create a light and airy space in your home. This addition to your kitchen or living room can truly change the feel of your home and give you the space you crave while adding significant value to your property.

## Lose those Steel Beams

Often orangery roofs are specified with loose timber and steel beams for the roof construction, as a direct consequence of this the roof can often be unnecessarily

complicated and expensive. Lantern weights are commonly more than 500kg and must have the appropriate support in place.

Our unique metal web joists provide the perfect solution to these requirements. Offering superb levels strength, our metal web joists can remove the need for these steel support beams.

The properties of our metal web joists, in comparison to solid timber or alternative engineered timber beams, combined with the lightweight nature of the metal web joist system, resulting in a solution that's easy to handle and install.

In conjunction with our latest design software, our unique metal web joists allow the designer to manipulate the joist end details to suit intricate design details that are commonplace in orangery design. Alternative products cannot offer this versatility.

These intricate details include, but are not limited to:

- Parapet wall details
- Hanging from ledgers fixed to the existing structure
- Fixing into steels to create openings into the new structure
- Soffit/gutter detail requirements

## Why use Wombourne Windows for Orangeries?

We've been working in the orangery industry for many years. During this time, we have built up extensive know-how on the best design and detailing methods. Our projects are usually the most design intensive due to a variety of roof loading considerations such as snowdrifts, wind uplift lantern weights and many more.

Orangeries are relatively quick to erect, in these quick turnaround projects, our lead-time promise comes into its own, offering a technical site survey and full Architectural services if required.





## Wombourne Windows Tiled Roof

The lightest tiled conservatory roof available, Ultraroom is both easy and fast to fit with an unrivalled quality finish. Ultraroom has superior strength for larger designs and NEVER needs a tie bar. Each roof is precision engineered to wind & snow load requirements of the postcode of the installation.

A U-value of 0.17 as standard with the option to reduce to 0.13 if required, the Ultraroom is the most thermally efficient warm roof system on the market.

Full length glass panels provide a cost effective and stylish way to project more natural light into the room vs conventional rooflights.

With no cutting and drilling required, components labelled in sequence and tiles pre-cut to size in panels of 12, Ultraroom is easier and faster to fit than other tiled roofs.

The only lightweight tiled roof to be Independently and fully fire tested, Ultraroom is rated as B-roof to EN 13501-5:2016 and AC according to BS476-3:2004.

Ultraroom's, unique authentic lightweight tiles in grey, brown or terracotta together with an optional curved cornice, deliver a distinctive high quality finish.

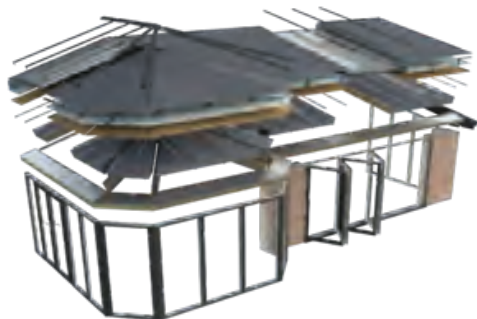



# *Premium*



origin

DOORS

# BI-FOLD DOORS



# BI-FOLD DOORS

## Aluminium vs Timber vs uPVC - Which is Right for Me?

When installing doors or windows, choosing the right material is one of the most important decisions you can make. It will impact the strength, security, longevity of service, and possibly even the value of your property. The three main materials are aluminium, timber and uPVC. Here, we compare these materials to highlight each one's strengths and weaknesses.

Here are 7 things you can do to successfully incorporate windows/bi-fold doors into your extension:

- Consider where the sun is
- Maximise the use of glass
- Bring in light from above
- Have a dual aspect extension
- Be prepared to reconfigure
- Consider the internal appearance
- Think about temperature, not just light

	Aluminium	Timber	uPVC
Strength	Aluminium is innately strong, so it can achieve very slim sightlines. Because of its strength, it also means that individual panels can often be larger than other materials.	Timber is strong, but it can absorb moisture, corrode and become infected with mites, which can compromise its overall strength and rigidity.	uPVC is the weakest material, which can affect both security and visibility. Because it's weak, sightlines are often wide so it can accommodate the glass weight.
Maintenance	Aluminium is low maintenance and only requires a clean every now and then with a diluted soapy water solution.	Timber requires regular maintenance, including waxing, painting or using treatments to prevent rotting.	uPVC doesn't require much maintenance. However, the colour finish tends to fade quickly.
Thermal efficiency	Aluminium is not naturally a good insulator. However, some manufacturers, like Origin, incorporate a thermal break within the profile to meet current building regulations.	Timber is naturally a good insulator. However, it can contract in the cold which can lead to gaps, compromising its thermal efficiency.	As uPVC is plastic, it's a very good insulator. However, if it warps or flexes, then energy performance and overall operation can be drastically reduced.
Environmental impact	Not only does aluminium have the best longevity out of these materials, but it's also infinitely recyclable and therefore more environmentally friendly.	Timber can't be recycled as many times as aluminium, and the process of obtaining timber requires cutting down trees.	uPVC can also be recycled but not as many times as aluminium.
Property value	Aluminium can boost the value of your property as it provides many long-lasting benefits.	Depending on the property style, timber can add to the value of your home.	uPVC can add an initial bump to the property value, but aluminium is becoming more expected in higher valued properties.
Guarantee length	Aluminium can offer long guarantees. Origin offer an industry-leading 20-year guarantee for its doors and windows.	The average guarantee length for timber doors and windows is between 6-10 years.	uPVC guarantee lengths tend to be much shorter than aluminium and timber, approximately 5-10 years.

So, if you're looking to add value to your property, benefit from low maintenance and a long guarantee, then aluminium doors and windows are the right choice for you. If you like the timber look and feel, you can achieve a very realistic finish with aluminium powder coated woodgrain effects.

## Bi-folding Door Thresholds FAQs...

### What is a bi-fold door threshold?

A bi-fold door threshold is the track in which the carriage slides in that allows the door to open and close.

### What threshold options are available for the doors?

Wombourne Windows offers two types of threshold:

- Non-weathered threshold - this is when the track is almost completely flush to the floor.
- Weathered threshold - also known as a 'rebated' threshold, it features a small lip on one edge of the track. The seal on the bottom of the door compresses against the lip to create a weather tight seal.

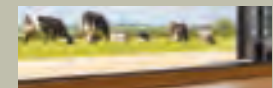

Weathered threshold



Non-weathered threshold

## Hardware, Components and Accessories...

Little things that mean a lot

We've left nothing to chance in the creation and manufacture of the Origin Door. Every detail has been scrutinised, every process meticulously tested and every component designed to ensure all elements perform flawlessly.







Low Maintenance



Safe and Secure



Free Glide System



Thermal Efficient



### Bi-fold Door

The door that started it all.

Origin Bi-fold Doors come in configurations ranging from two to twelve door sets, and can create an entirely new living space - all it takes is a gentle push.



### Handled with Care...

The handles of our doors are the perfect finishing touch to the exquisitely designed system.

In addition to striking the optimum balance between superior strength and sleek design, our handles are exhaustively cycle tested so they mirror the flawless functionality of the doors, ensuring they stand the test of time.

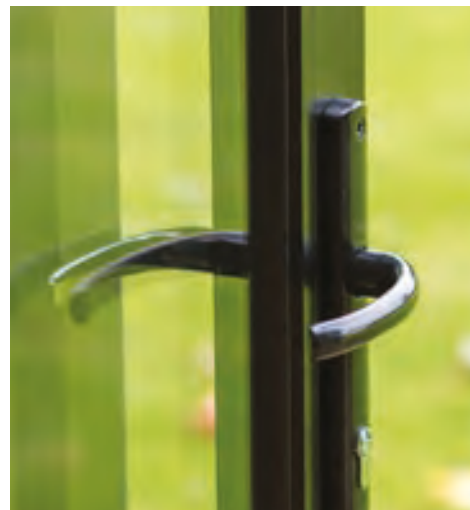

### OB-49 Handles: Stainless Steel Range



Solid stainless steel lever handle with separate escutcheon

Solid stainless steel handle with long back plate

### OB-72 handles: Popular Aluminium Range



Security handle with lever in white

chrome

black

gold

### OB-72 Handles: Stainless Steel Range



Solid stainless steel lever handle with separate escutcheon

Solid stainless steel handle with long back plate



# SASH WINDOWS





# SASH WINDOWS



## An Historic Perspective

First introduced in the mid-1600s, the sash window has always been simple in design and yet very elegant. As such it quickly became both fashionable and desirable, a symbol of wealth amongst the rich. Throughout the 18th century aristocrats used sash windows to replace casement windows previously installed in 16th century properties.

Shortly after the Great Fire of London in 1666, it was found that timber signs, oak beams and wooden windows had accelerated the spread of the fire and resulted in the borough of London changing its building regulations. Hence it became a building requirement that window frames be recessed behind the outside brick or stone wall and set back from the front of the building facade, which gave birth to what we now recognise as the 'Georgian' architectural style.

You may be surprised to learn that the benefits of having two sheets of glass closely bonded into a sealed unit was first patented by Mr Thomas Stetson in 1865, making "double glazing" over 150 years old!

Sadly, since the 1960s the indiscriminate replacement of sash windows using mass produced, inappropriate PVC-U casement windows has resulted in thousands of original sash windows being lost, destroying the character and value of many properties in the process.



The sash window however, remains the most efficient ever invented. By opening both the upper and lower sash a few inches, really efficient purge ventilation is achieved, removing stale air quickly and inducing air circulation like no other.

You'll find we're attentive to the finer details too, and totally committed to creating authentic sash windows, with the proportions and elegance of the originals, but with all the attributes demanded by modern living.

## Conservation Areas and Article 4 Directives: Retaining character

Any building of importance will be listed to some extent, for its own protection and to safeguard the special character of its neighbourhood. Because so many buildings have had their charm and character destroyed by inappropriate replacements, PVC-U has become associated with inferior casement windows installed in the 1980s. This has led to the widespread rejection of replacements through planning restrictions, regardless of authenticity.

Unfortunately, many officers considering applications still retain these outdated perceptions and refuse applications, without considering the vast improvements made in recent years.

Our installation partners are experienced in dealing with your local planning and conservation departments, and many have been given the green light for projects in conservation areas, because the windows are so good. Do feel free to discuss any worries or concerns with your nearest installer.



### What Makes our Sash Windows so Traditional?

To ensure you'll have beautiful windows, we've taken the time to study original sash windows and to recreate the critically important details like these;

- Slim sight-lines through both the upper and lower sashes maximises the visible glass area.
- Equal panes in both sashes creates a balanced appearance consistent with original timber sash windows.
- External staff bead detail on the frame and an option for internal staff bead trims, to conceal the inner workings of the window, just like old sash window boxes.
- Continuous run-through sash horns (not shiny plastic clip-ons), utilised by the Victorians and designed to place more material below the mortise, therefore strengthening the stile.
- A traditional, butt jointed deep bottom rail (DBR) and bespoke sash sections, ensure the appearance is appropriate, rather than four sections of the same width simply welded together.
- Our grained acrylic foil finish is designed to look like painted timber.
- We offer a variety of wood grain effect, textured finishes. These finishes create a stunning painted wood appearance, providing extremely low maintenance and their durability extends the life of a standard PVC-U shiny plastic finish.



## Bygone Harmony

- Unique 12 year guarantee
- A Rated for energy efficiency as standard
- Secured by Design as standard – a police approved accreditation for complete peace of mind
- Patented Timberweld® technology for perfectly sealed corners
- Manufactured in the UK using components sourced in the UK
- Wood grain foil
- Exclusive putty line appearance
- Bespoke Bygone furniture in a range of colours
- Continuous hand finished waxed horns
- Slim integral mullion for multi-light windows as standard
- Deep bottom rail or large butt jointed bottom rail
- 39mm 'Super Slim' meeting rail
- High grade Torso balances tested to last 50 000 cycles and more – an average life expectancy of 68 years\*
- GRP deep cill as standard optional PVC-U cill.
- Patented design features



## Bespoke Furniture

Traditionally, scroll handles or cups were fitted on windows internally and D handles under the top sash were fitted externally. Most home owners prefer something visually appealing that can be reached easily from the inside.

Our furniture is colour suited and manufactured by the same UK based hardware company, therefore you will find all the components match and you certainly won't find an assortment of odd colours.

All Bygone windows come with two scroll handles and a single ring pull for the upper sash. Don't worry, we also offer bespoke oak handled poles to reach the ring pull.

## Pole Eyes and Scroll Handles

It is customary to have a ring pull or pole eye fitted to the centre of the top rail on the upper sash (a branded pole hook can be supplied if required). Alternatively, a "D-Handle" can be fitted to the underside of the top sash externally, if requested.

## Bespoke Locks and Restrictors

When you're investing in new windows, you'll want them to work well and look fabulous forever.

Our design team have looked at hundreds of standard cam catches. These range from thin zinc alloy imports, to chunky industrial locking systems that lack finesse. Having helped write the UK's first security standard for sash windows, we knew the structural loads and requirements needed, but also understood the primary features had to be good looking.

There is now a choice of three distinctive designs and a number of different colour suites. The bespoke Bygone

furniture is available in a Beehive, Acorn or Porcelain Ball style and comes in Antique Brass, Chrome, Pewter, Satin Chrome or Black.

Each cam catch has its own suited Allen key with ball top and you'll find the other window furniture, including limit stops and handles, suites perfectly. When you're investing in new windows, you'll want them to work well and look fabulous forever.









## Unique Styles & Shapes

Our sash windows can be manufactured in a variety of styles and shapes, allowing you to match your existing window design.

Bygone windows can offer most Georgian bar designs and even some less traditional ones. We can also manufacture to specific visible glass sizes or line through with existing windows and doors.

Whilst single sliders are common place, coupled or multi-lights are regularly requested. Remember that Symphony and Harmony will have the slim integral mullion as standard, which reduces sight-lines by more than 50mm.

We are often asked to make windows with arched heads of varying degrees. Whilst a 'true arch' will have a full semi-circular head, a shallow arch or 'swept head' will have a much shallower radius. In the case of 'true arches' the top sash will always need to be fixed and will not slide. Occasionally, our installers are asked to supply windows that are square on the inside, with a swept head on the frame outside. Even these are possible and they're simply known as 'The London sash'.

We appreciate that your home is likely to be your single biggest investment and for this reason we really don't mind you obsessing over the finer details, in fact we encourage it! Please feel free to discuss any unusual shapes or one-off designs with your Bygone installer, they're there to help. If you have something particularly complicated, we can even provide technical drawings to help you visualise the final design.

## Typical Styles & Patterns

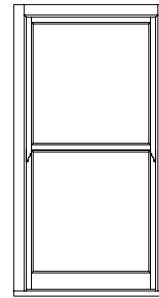

Non Bar

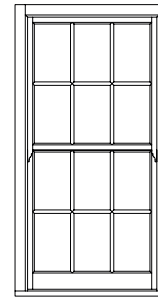

Full Georgian

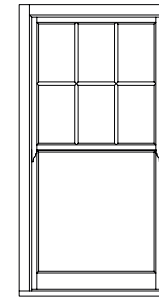

Half Georgian

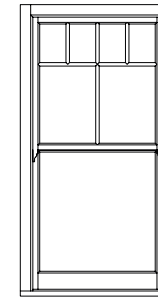

Georgian Variant

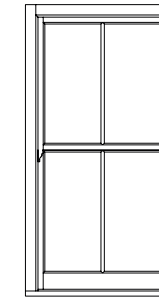

Centre Bar

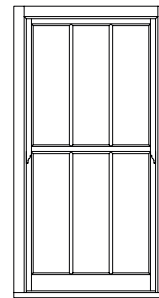

Three Light

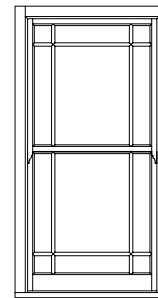

Marginal Border

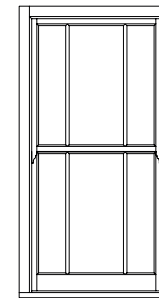

Marginal or 'Off Set'  
Three Light

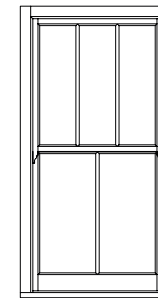

Aysymmetric

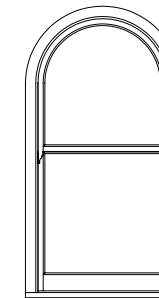

True Arch

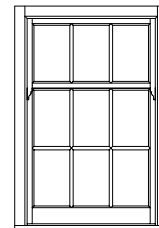

1/3rd Split

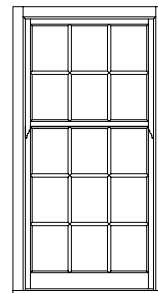

2/5ths Split

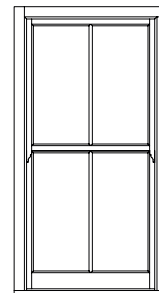

Slim mullion Style 2

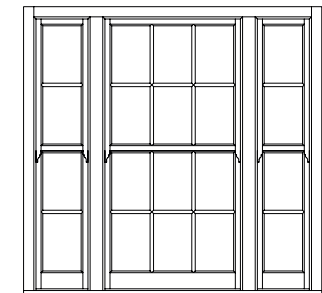

Slim mullion Style 3

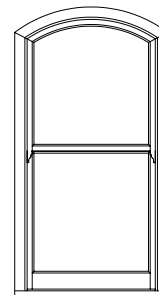

Swept Head

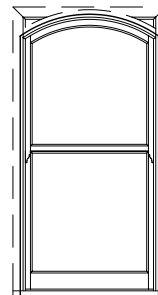

London Sash  
& Frame

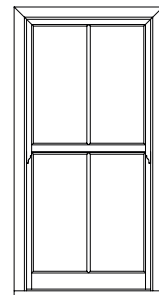

Coupled Style 2

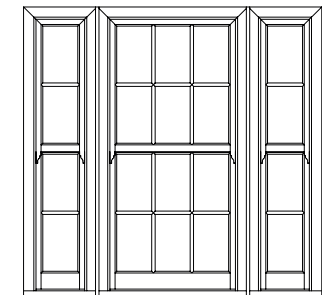

Coupled Style 3

*All windows depicted show mechanical butt jointed construction and slim mid rail*



# ORTON & HIMLEY TIMBER RANGE



# ORTON & HIMLEY TIMBER RANGE

Orton & Himley timber home improvement products are a luxurious addition to your home, exuding classic charm whilst providing all the energy efficiency and security benefits of modern timber windows, doors and conservatories.

Every product is designed with durability in mind so whichever look you go for you can be confident it will stand the test of time.

The Orton & Himley timber range is suited to every type of property, from townhouse to modern apartment. This section showcases the range of styles, colours and hardware options on offer to help you find the perfect look for your home that fits in with your individual tastes too.

## Timber Species

All timber used for the Inspire range is responsibly sourced from renewable forests, helping to protect the world's natural resources.

Choose Accoya...

With the correct maintenance, finished timber home improvement products will last up to 50 years without needing to be replaced.

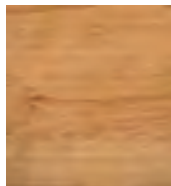

## Accoya

Accoya is a high performance, modified timber made from sustainably sourced softwood. Its durability is labelled as 'Class 1', the highest level of durability for timber.

The 7 degree bottom rebate slope ensuring that any water that does penetrate the external glazing seals is allowed to dry out and in extreme cases drain out.

## Durability by Design & Finishing Process

To ensure you're getting the best products for your home, the timber the Orton & Himley ranges are designed with sustainability and durability in mind.

Research into high technology timbers, new timber finishing products, and modern manufacturing techniques means your new windows, doors or conservatory will require less maintenance and perform better for longer.

A drained and ventilated glazing system featuring a 7 degree slope to the bottom rebate is incorporated into the design of the externally beaded "Orton & Himley" Timber Windows and Door sets (excluding Georgian Bar and some bespoke designs eg. Shapes).

This Design Feature is critical to the "Durability" and long term performance of the product giving added protection against rot and premature failure of the Double Glazed Unit. Products are factory finished in a range of high performance microporous colours and stains.



## Orton & Himley Windows

Orton & Himley timber windows are an ideal replacement for double glazed PVCu windows if you want a more traditional look. They can also replace original single glazed timber windows to help improve the energy efficiency of your home.

Maintain the classic appearance of your home with traditional sliding sash styles or opt for a casement style for a cleaner, more contemporary look which still has all the aesthetic appeal of a real timber window.

Not only do our new windows look absolutely stunning, they require much less maintenance and have helped reduce our energy consumption.



## Himley Stormproof Casement Windows

Stormproof windows are designed for areas with harsher environments where extra protection against the elements is needed. The classic design of Inspire timber Stormproof windows never goes out of fashion, giving you an attractive replacement window which will also help weather-proof your home.

Himley Stormproof casement windows can be matched to your existing windows or feature unique details for a stand-out look. A range of sill, frame thickness, sash options and hardware are available, for a truly bespoke look that suits all types of property.

Himley Windows timber Stormproof casement windows can be finished in an opaque colour or translucent stain, both of which are moisture resistant to give your windows further protection from the elements.

**Available in the following wood option: ✓Accoya**



## Himley Flush Casement Windows

Himley timber flush casements give you a traditional look with a fuss free finish and are ideal for conservation projects where this style is a staple feature of period properties. Himley flush sash windows replicate the original but are designed with a range of innovative features for modern window performance.

Casement is one of the most versatile styles of window. Windows can be top hung, bottom hung or a combination of these. You can even create bay and bow styles which are popular in older properties.

To complete an authentic period flush sash window look, there are a range of colours to choose from for an original painted timber window look, along with traditional style hardware in a variety of finishes.

**Available in the following wood option: ✓Accoya**



## Orton Sash Slider on Spiral Balances

Timber sash windows are a typical feature in many older properties, but are a popular style for both period and modern homes. Inspire timber sash sliders on spiral balances are a modern solution to weights and pulleys sash windows, giving you the look of a traditional box sash window combined with modern technology.

This style is suitable for newer homes as it doesn't require the deep reveals for fitting traditional weights and pulleys window so can easily replace more modern PVCu systems.

Traditional ironmongery is available with Inspire timber sash sliders for an authentic look but modern details such as an optional tilt-in facility for easy cleaning make this style easy to maintain.

**Available in the following wood option: ✓Accoya**

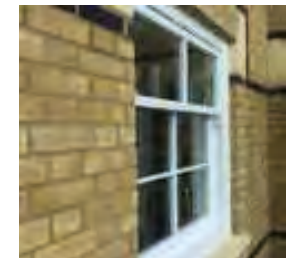
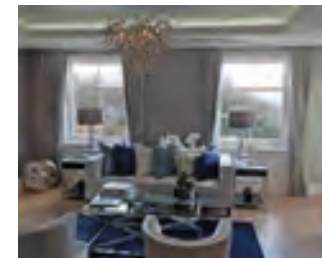



## Orton Sash Slider with Weights and Pulleys

The ideal replacement for original timber box sash windows, Orton timber sash sliders are designed to replicate original weights and pulleys systems with as much accuracy as possible.

Unlike traditional single glazed box sash windows, Orton timber sash sliders use a timber section size which can accommodate double glazing. Replace your old sash windows like for like and improve your home's thermal efficiency.

Features of the window include a deep bottom rail, run-through sash horns and Georgian bars, with a choice of traditional style hardware and opaque or translucent colour options for a look that's just right for your home.

**Available in the following wood option: ✓ Accoya**

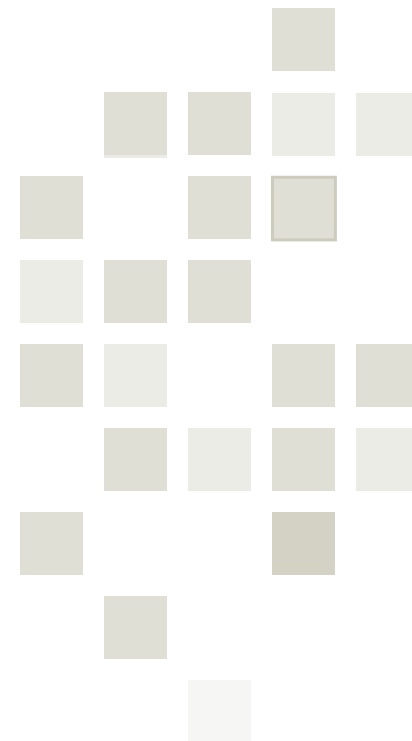



## Himley Doors

Find the ideal door for your home in the Inspire timber collection. Styles range from traditional to more contemporary solutions depending on the look you want and type of property you live in.

Refresh the entrance of your home with a traditional style timber residential or French door. Or if you want something with extra wow factor, Inspire timber bifolding doors are an impressive feature in any home.

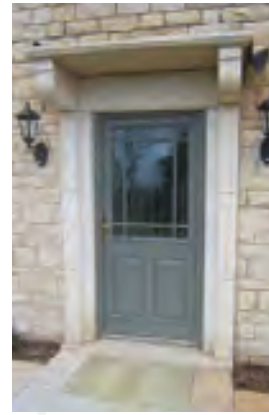

## Himley Residential Doors

Turn heads with an attractive new entranceway that combines traditional style with modern performance and security features.

Whether you live in a townhouse or cottage, modern apartment or detached home, there's an Himley door to fit in with your property and personal preferences. Create any design you like, solid or glazed, along with additional style details such as arches and side panels.

Inspire residential doors are designed to be durable and secure. A three point dead-bolt lock and anti-bump, snap and drill cylinder helps protect your home from would-be intruders, giving you peace of mind.



**Available in the following wood option: ✓ Accoya**

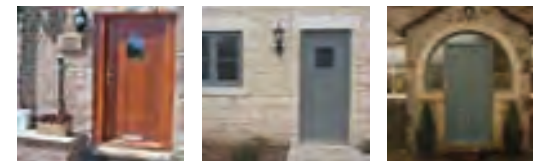



## Himley French Doors

Himley French doors suit almost any type of property, letting light into your property and providing an alternative to a standard PVCu entrance door onto a garden or patio area.

Minimal modern as well as classic styles can be achieved, including arched head designs and Georgian bar details, to create a look that's just right for you.

Best of all Himley French doors are designed with sustainability and security in mind. Be confident knowing your new door is built to last a lifetime and is fitted with a three point dead-bolt lock which is proven to resist the three main burglary attack methods: bumping, drilling and snapping.

**Available in the following wood option: ✓ Accoya**

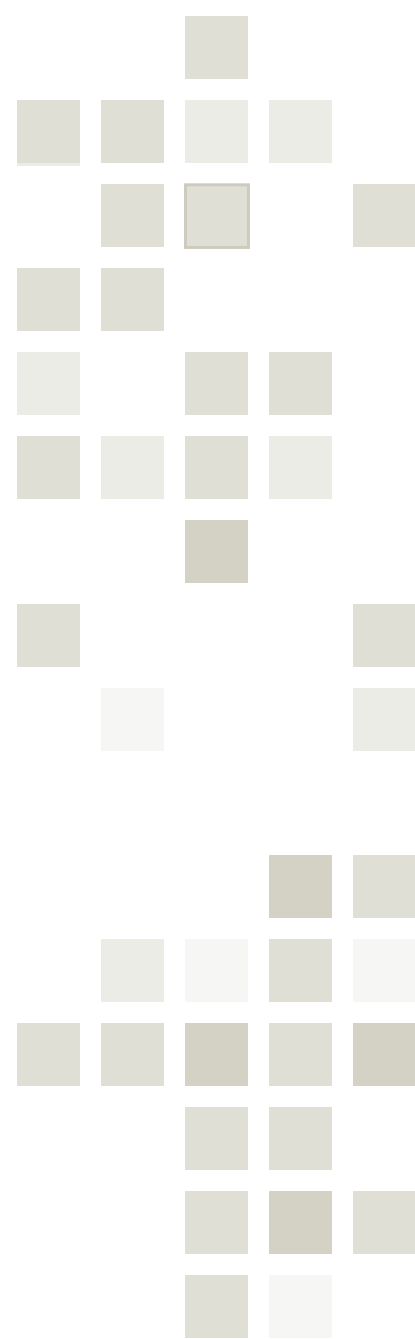

## Himley Bi-folding Doors

Himley bifolding doors are a modern twist on traditional French and sliding patio doors. They have the ability to completely open up a space, making it brighter, and giving your home the illusion of being bigger.

Himley bifolding doors can have up to seven panels and span a width of seven metres. Open up your new door in summer for beautiful, uninterrupted views to outside, and in the winter sit back and relax knowing your Inspire bifolding door will help keep your home warm.

Choose from a range of colours and finishes to match your new or existing windows and the brickwork of your home.

**Available in the following wood option: ✓Accoya**



## Himley & Orton Glass Options

Himley & Orton timber windows can be installed with single or double glazed patterned glass in a range of different styles to add character to your home.

Patterned glass can be used to closely match or replace an existing window pattern, or as an attractive way to maintain privacy in your home.

The degree of obscurity will vary depending on the glass, but our patterned glass options are designed to still allow natural light to enter a room.

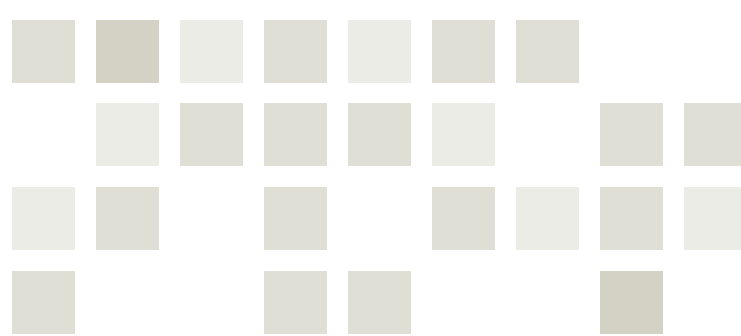
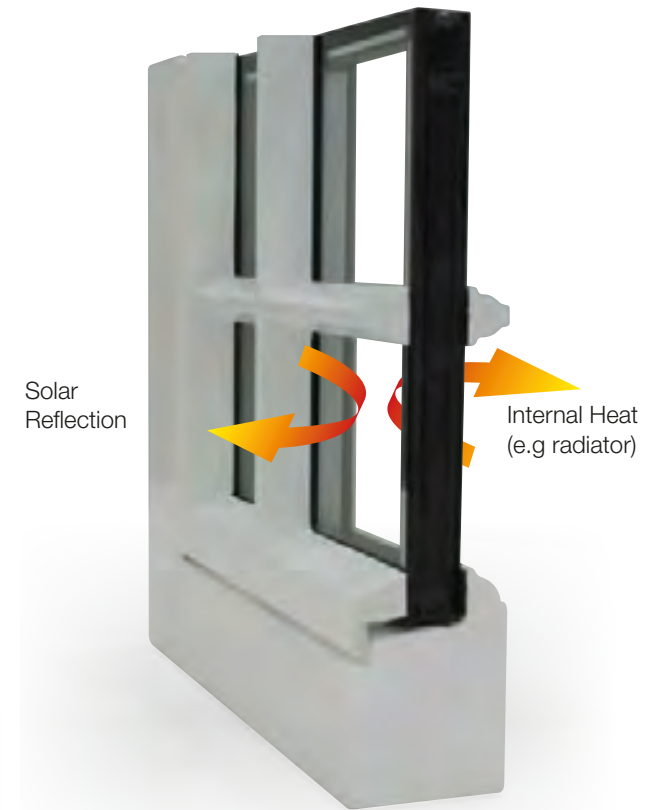
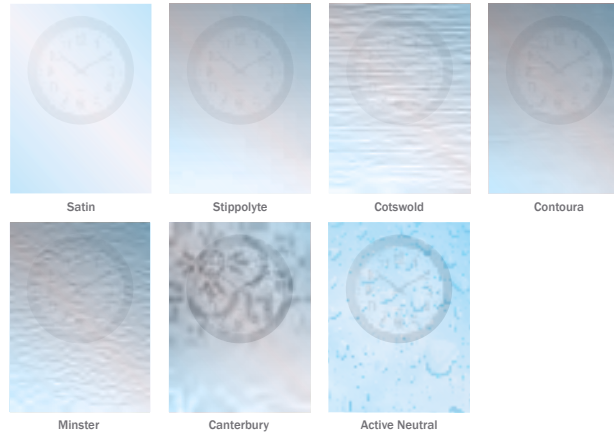



## Himley & Orton Leaded Glass and Astragal Bars

To replicate the appearance of various styles of original timber windows, you can have Himley & Orton timber windows fitted with leaded glass or Astragal bars.

Leaded glass designs can be created to match existing patterns but the most popular style is diamond pattern leading.

Astragal bars were a common feature on traditional timber windows and Himley & Orton windows can incorporate Astragal bars to recreate this look.



Leaded Glass



External Georgian Bars



Internal Georgian Bars



## Himley Window Hardware Options

The finishing touches for your new timber windows are the handles. Choose from lots of different finishes to complement the colour scheme of your home, or to create a focal feature of the window.

### Window Handles



Antique Black Black Chrome Gold Bronze Satin White Graphite



### Teardrop Handles

Choose a teardrop handle for a more traditional appearance. They give an interesting style detail that looks good in all types of home.

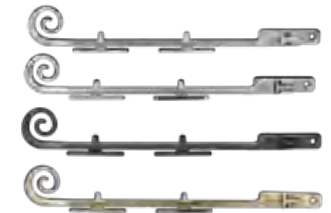

### Monkey Tail Handles

First seen on the original timber windows of yesteryear, monkey tail handles are an easy way to add a traditional vibe to your windows.

## Himley Door Hardware Options

Lever, Swan Neck and Lever Pad Handles

Available in: Antique Black, Black, Bronze, Chrome, Gold, Graphite, Satin & White.



### Letterplates

Alongside stunning door handles and door knockers, the Inspire range also includes matching letterplates.

### Timber Door Hinges

Available in: Black, Chrome, Dark Brown, Gold, Satin, Tan & White.

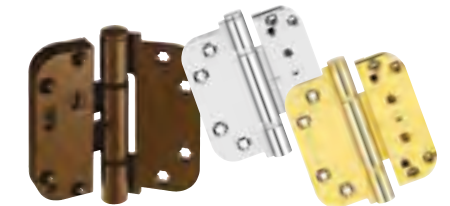

### Knockers & Spyholes

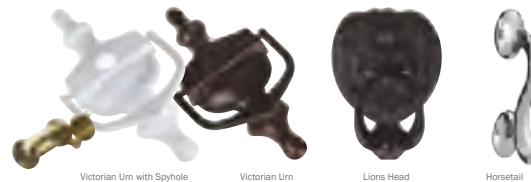

Victorian Urn with Spyhole Victorian Urn Lions Head Horsetail

The first interaction someone will have with your home is when they knock on the front door, so make sure you create the right first impression with a stylish door knocker. From the traditional to the contemporary, we offer door knockers to suit any home. We also offer a selection of spyholes so you can see who is outside before opening!

We reserve the right to change our ironmongery range

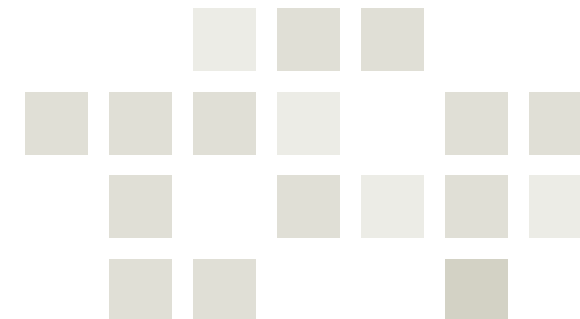

## Himley & Orton Colour Options

Himley & Orton timber home improvement products are available in a range of colours and finishes to match, or stand out from the rest of your home's style. Or any RAL by special order.

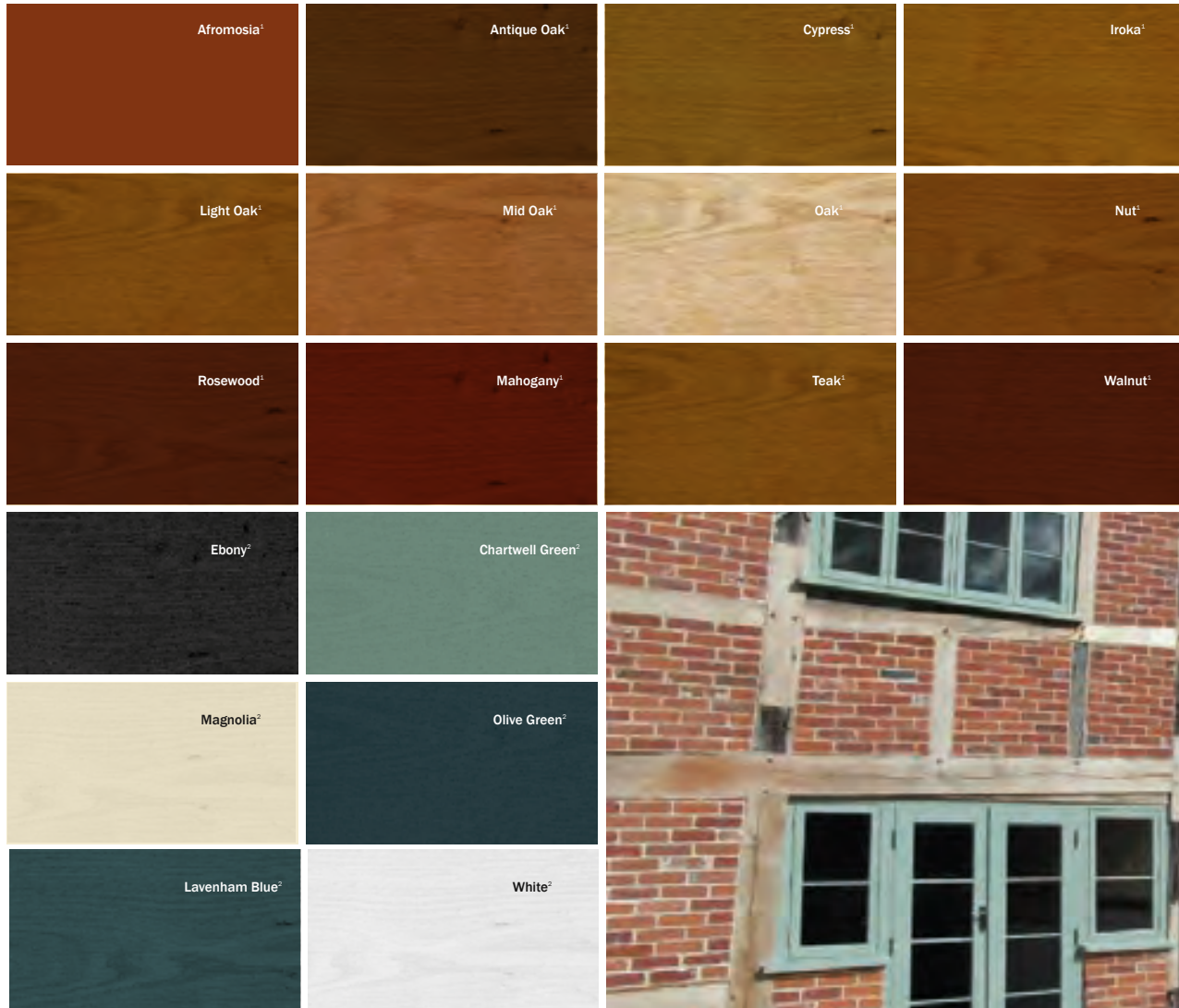

## Opaque Colour<sup>2</sup>

Traditionally, timber windows were always painted, and you can achieve this look with the opaque colour range. This includes any of the 1,900+ shades in the RAL colour spectrum, giving you a huge range of choice.

*Our timber range is available in any colour and can be colour matched to suit your existing property.*

\* We can even match Farrow & Ball colours.





## Orton & Himley Security

Unsecure windows and doors are vulnerable to potential intruders but with Inspire you can be confident your home will stay secure.

Orton & Himley timber windows and doors are fitted with high performance locking systems, with doors featuring a three-point dead-bolt lock and anti-bump and drill cylinder, and cylinder guard. This protects the door from the three main burglary attacks – bumping, drilling, snapping – keeping you safe.

## Secured by Design

Secured by Design is a police initiative put in place to improve security measures in homes across the UK. By choosing home improvement products that meet these standards you can be confident your property will stay secure.

The following Orton & Himley timber products are Secured by Design accredited. Please note other products can be modified to Secured by Design specifications if needed:

- Stormproof casement windows
- Residential doors
- Vertical slider on spiral balances windows



*All of our Orton & Himley window and door products are fitted with the latest high security locking mechanisms from leading suppliers.*





AL-ELEGANCE



# AL-ELEGANCE

## Our Exquisite Bespoke Windows, Doors and Screens

The Wombourne Windows Collection offers exceptional steel look architectural glazing solutions, meticulously designed to transform your living space into something truly extraordinary.

From our iconic steel replica range of exterior windows and doors, we offer a unique solution to you and your home.



## Designing Spaces to Enhance Your Home

We have an exceptional reputation, where attention to detail and superb British craftsmanship is second to none.

We specialise in the design of iconic steel effect windows, doors and screens covering exterior applications, for truly luxury living.

The Wombourne Windows Collection is available in an extensive selection of colour and finish options, including a stunning range of traditional and contemporary furniture and ironmongery styles and designs to compliment your home.



## Creating Lasting Impressions Through Interior Design

Attention to detail is at the core of the Wombourne Windows experience. Our range of exceptional windows and doors are designed to ensure every detail is captured.

Slim and equal glass sightlines maximise glass area and provide uniform appearance to folding doors; colour suited furniture to seamlessly match your windows and door frames; dual colour finishes to allow different internal and external designs; and handle designs to suit every room in your home. All can be tailored into every Wombourne Windows product to suit your needs.



## Timeless Design, Advanced Performance

Our elegance collection is inspired by traditional, industrial steel windows and the highly sought after Scandi-style. Combining cutting edge technology with artisan designs and craftsmanship, we create striking but minimalist metal frames, featuring slim sightlines and the iconic grid-like designs, with styles that range from classic heritage to contemporary. These versatile windows and doors have the ability to completely transform your home, letting in more light and creating luxury living spaces.



## Exterior Steel Look Collection

The Wombourne Windows steel look system uses modern high performing materials to create traditional steel look style doors, screens, partitions and windows. Delivering classic industrial finish products with slim sightlines, to provide maximum natural light whilst delivering thermal, security and weathering performance.

### Key Features

- Fully crimped and glued corner joints for strength and weather sealing.
- Range of shapes, raked and arched windows, doors and screens
- Very slim sightlines to maximise glass area and light
- Powder coated paint for durability and quality. Available in a range of smooth and textured finishes
- 28mm warm edge, argon filled double glazed units to all products. Doors and side screens toughened safety glass as standard
- Security multi-point locking to all windows and doors, designed specifically for steel look products
- Thermally broken profiles for enhanced energy performance
- Toughened single glazed option for all internal, doors, screens and partitions
- No threshold on internal doors for seamless flow of floor covering
- Bespoke hand crafted manufacturing of all products in the UK

### Check List

- Thermal broken powder coated steel look frames  
**Wombourne Windows ✓ Steel ✗**
- 28mm double glazed and single glazed options  
**Wombourne Windows ✓ Steel ✓**
- Multi-point security locking to all windows and doors  
**Wombourne Windows ✓ Steel ✓**
- Comprehensive shaped frame options  
**Wombourne Windows ✓ Steel ✓**
- Interior and exterior door, screen, partition and window configurations  
**Wombourne Windows ✓ Steel ✓**
- Equal glass sightlines for all products  
**Wombourne Windows ✓ Steel ✓**
- Range of furniture styles and options  
**Wombourne Windows ✓ Steel ✓**
- Air, water and wind resistance to 300Pa, 600Pa and 2400Pa respectively  
**Wombourne Windows ✓ Steel ✓**
- Manufactured in the UK  
**Wombourne Windows ✓ Steel ✓**



## Exterior Collection Furniture Window & Door Range

The range of standard window and door handles are both available in colour matched white, black, gold and chrome finishes.

Standard on all Exterior steel look window and doors.

### Window Handles



BULB END  
WINDOW  
HANDLE



BLACK MAXIM  
WINDOW  
HANDLE



WHITE MAXIM  
WINDOW  
HANDLE



GOLD MAXIM  
WINDOW  
HANDLE



CHROME MAXIM  
WINDOW  
HANDLE



SATIN CHROME  
MAXIM  
WINDOW  
HANDLE

### Door Handles



BLACK  
WINDSOR  
DOOR  
HANDLE



WHITE  
WINDSOR  
DOOR  
HANDLE



GOLD  
WINDSOR  
DOOR  
HANDLE



CHROME  
WINDSOR  
DOOR  
HANDLE



SATIN CHROME  
WINDSOR  
DOOR  
HANDLE



## Hardware Options

Complete your door design with a range of beautiful accessories.

We offer a stunning range of hardware for your door, in a wide choice of colour options with both classic and contemporary styles.



\*Pull Bars not available in Secured by Design  
Offset Pull bar only use for 44mm doors  
Straight Pull bar only use for 68mm

		Chrome	Gold	Satin	Black	White
<b>Classic Accessories</b>	Lever Lever Handle	✓	✓	✓	✓	✓
	Lever Pad Handle	✓	✓	✓	✓	✓
	Letterplate	✓	✓	✓	✓	✓
	Urn Knocker	✓	✓	✓	✓	✓
	Urn Spy Knocker	✓	✓	✓	✓	✓
	Affinity Knocker	✓	✓	✓	✓	✓
<b>Contemporary Accessories</b>	Doctors Knocker	✓	✓			
	Pull Bar (550 - 1800mm)					
	Bow Bar (550 or 750mm)					
	Escutcheon					
	Pull Escutcheon	✓	✓			
	Pull Knob					

### Single Rebated 44mm Thresholds

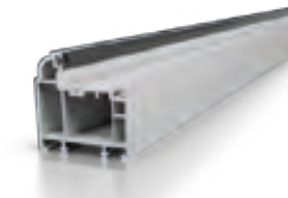

#### Sculptured PVCu

Colours suitable for single rebated doors available to match all frame colours. (Available for double rebate)



#### Part M Aluminium

Suitable for single rebated doors available in anodised silver or gold finish.

### Double Rebated 68mm Thresholds



#### Chamfered Aluminium

Thermally broken Aluminium threshold suitable for double rebated doors available in anodised silver or gold finish.



#### Sculptured Aluminium

Thermally broken Aluminium threshold suitable for double rebated doors available in anodised silver or gold finish.



#### Part M Aluminium

Thermally broken Aluminium threshold suitable for double rebated doors available in anodised silver or gold finish.

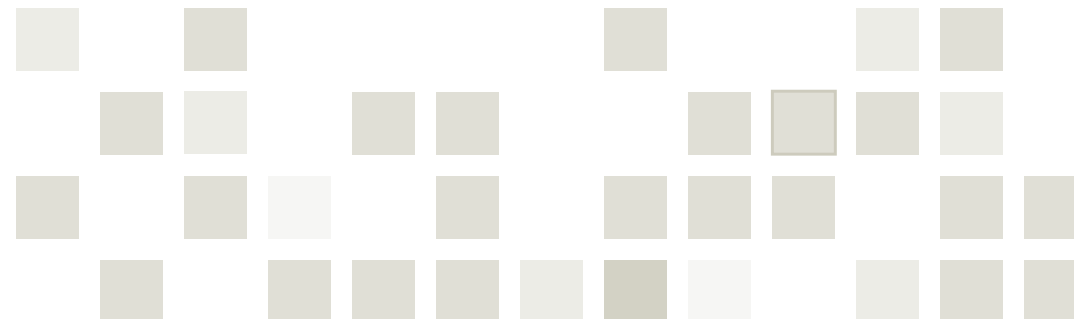





ROOFLINE  
PRODUCTS

# ROOFLINE PRODUCTS (FASCIA SOFFIT AND GUTTER)

## Wombourne Windows Ltd Full Fascia Replacement

Full replacement involves removing the existing wooden fascia and replacing it with a new PVC fascia board. During this process the felt that guides rainwater into your gutter can also be checked and replaced to ensure your roofing performs properly.

We will remove all of the existing fascia boards, and guttering if you have a cement board soffit we will leave this in as this is part of your fire break, but be assured this does not rot, so we are ok to offer a beautiful hollow cell board in your choice of colour to cap this area. We will repair any damage to the rafter feet to ensure a solid fixing for the new products. An eaves protection system will then be installed where applicable. This is a rigid plastic tray that sits under the first row of tiles and bends down outside the tile to guide rainwater into your new guttering.

We will then install new replacement 18mm thick fascia board. This would include the installation of an over fascia vent system should it be necessary. (This is a linear vent that sits on top of the

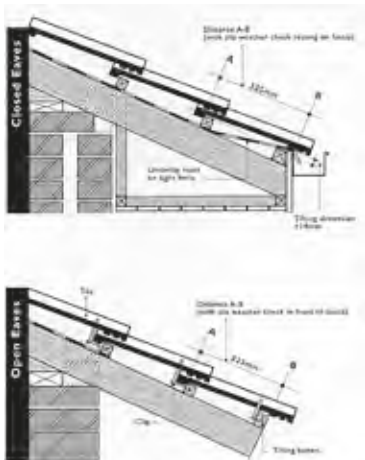

fascia board and under the tiles/slates). This is the standard applied to all new builds and will ensure that the attic space is ventilated correctly as far as the roofline is concerned.

**A thorough job with no shortcuts - ensuring that your roofline will last for years and years to come.**



## Capping over fascia

You might be tempted to go for a cheaper “patch-up” repair of fascia instead of a full replacement. Known as a “cap over” in the trade, this involves removing the guttering then attaching a PVC fascia “cappit board” to the existing timber fascia. New guttering is then attached to the cappit fascia board. It is essential that the existing timber is sound – if it’s rotten it will continue to decay underneath eventually causing the cappit fascia board to fall off.

Capping over is a cheaper roofline repair option as the methods used are less substantial. It should only be considered if the existing timber fascia is in very good condition and free from rot. Attaching a PVC fascia board to rotten timber may cost you more in the long run!









# The Wombourne Windows Experience

The first step in your journey is to visit one of our Wombourne Windows showrooms. See for yourself the exceptional quality and design of our window and door collection, discover our range of finishing touches and discuss your project with an experienced designer.

When you choose a product from the Wombourne Windows Collection you're choosing more than just a supplier, you're choosing a dedicated team, unrivalled product performance and an unsurpassed passion for quality.

0800 085 8518

[www.wombourne-windows.co.uk](http://www.wombourne-windows.co.uk)

Email: [info@wombourne-windows.co.uk](mailto:info@wombourne-windows.co.uk)





# Wombourne Windows™

ORANGERIES AND CONSERVATORIES

Shrewsbury Showroom  
86 Wyle Cop,  
Shrewsbury,  
Shropshire,  
SY1 1UT

Head Office,  
Grainger & Worrall,  
Heathmill Road,  
Wombourne,  
South Staffordshire,  
WV5 8AP

Kingswinford Showroom  
The Rotunda,  
Townsend Place,  
Kingswinford,  
DY6 9JL

FREEPHONE: 0800 085 8518

